

# DATA SHEET

## EH RUBBER (10+6)

### EH 6

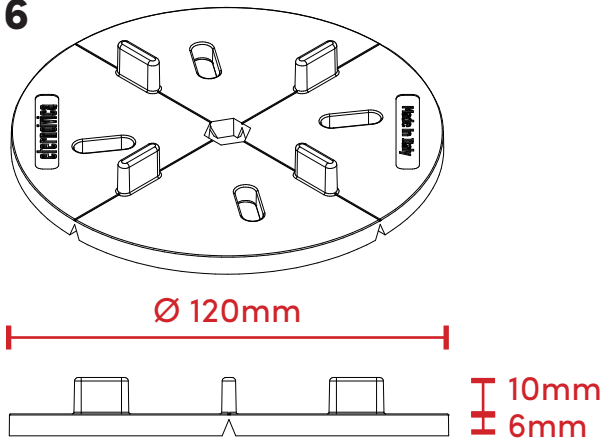

### EH 10

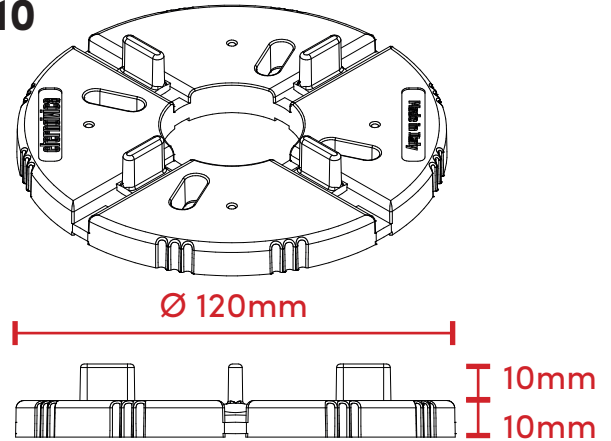

### TECHNICAL SPECIFICATION

Supply and installation of supports for "EHR" type raised floors. The supports are made up of fixed elements in SBS rubber, EH RUBBER 10 is 10 mm high, EH RUBBER 6 is 6 mm high, making it the lowest fixed rubber support for outdoor raised floors in the Pedestal line. Both can be used separately or stacked, until the desired required height is reached. The material is particularly resistant to sudden changes in temperature, acid solutions and atmospheric agents.

Subject to great crushing performance. It has a high property in noise reduction and its composition is specially formulated to match the high performance of the "white head" present in the NM and SE models of the Pedestal line. EH RUBBER 10 + 6 support can be used whole, in half or in quarter sections.

### CHARACTERISTICS:

- High thermo-chemical resistance
- Crushing resistance
- Noise reduction
- Can be sectioned into quarters

### RAW MATERIAL:

SBS

### ENVIRONMENTAL IMPACT:

recyclable material - not dangerous

### APPLICATIONS SURFACES:

On any outdoor installation area

### APPLICATIONS AREA:

Can be used with any prefabricated self supporting element for outdoor flooring

### GENERAL CHARACTERISTICS & PROPERTIES

	UNIT	VALUE	TOLERANCE +/-
<b>BASE DIAMETER</b>	mm	120	+/- 1.0
<b>EH 10 HEIGHT</b>	mm	10	+/- 0.2
<b>EH 6 HEIGHT</b>	mm	6	+/- 0.5
<b>TABS THICKNESS</b>	mm	4*	+/- 0.1
<b>TABS HEIGHT</b>	mm	10	+/- 0.1

The code refers to the model with 4 mm thick fins, 2 and 3 mm fins available on request

### ITEMS CHARACTERISTICS & PROPERTIES

COD.	DESCRIPTION	MEASURE	PCS. PER BOX
<b>E000010004</b>	EH Rubber 10 Support	20mmX Ø120mm	150
<b>E000006004</b>	EH Rubber 6 Support	16mmX Ø120mm	150

The packaging of the supports consists of cardboard boxes. The final packaging of the pallets is made with the wrapping of a polyethylene film. Indoor storage, protected from precipitation, is recommended.

**INSTALLATION METHOD:** The product is laid dry, without the need for adhesives or other types of fixings.

The above data are relevant to current production and may be changed or updated by Eterno Ivica at any time without notice. Given the many possible uses and the possible interference of external elements, we do not assume responsibility for the results. The buyer is required to establish under their own responsibility the suitability of the product for the intended use. This document is property of Eterno Ivica. All rights reserved.